

PRO 1000
HELP VIDEOS



PRO 1000 KIT INSTRUCTIONS

! DANGER

Ammunition reloading can be dangerous if done improperly and can result in serious injury or death.

! CAUTION

- Reloading should not be attempted by persons not willing and able to read and follow instructions exactly.
- Children should not be permitted to reload ammunition without strict parental supervision.
- Always wear safety glasses and hearing protection when reloading and shooting.
- Ammunition loaded with these tools and data should only be used in modern guns in good condition.
- We do not accept responsibility for ammunition loaded with these tools or data as we have no control over the manufacture and storage of components or the loading procedure and techniques.
- Primers and gun powders, like gasoline and matches, can be dangerous if improperly handled or misused.

Auto-Drum
powder measure
90811

Universal Case Feeder
90242

FOLDING PRIMER TRAY (1) included
#90606 (2 pack)

5/16-18 x 1 1/4 BOLT
(qty. 3) #FT2886

TOOL HEAD
#TR5031

PRIMER FEED SPRING
TR5386

PRIMER SLIDER TROUGH & PIN
#92021

PRIMER SLIDER
#BP5079

CASE RETAINER
#PR3691

BASE
TR3642

LINK BOLT (qty. 2)
TP2117

LUBRICATION POINT

CONNECTING LINK
#TP2129

LUBRICATION POINT

RAM

PRIMER OUTLET
TP3707

LUBRICATION POINT

LINK NUT (qty. 2)
FB1181

RAM PIN
OF3221

DISPOSAL TUBE # BP3064
CAP # BP3127

ROLLER HANDLE
#90746

CASE FEED SPRING
PR2118

INDEX ROD
TR5032

SLIDER BLOCK
#90497

CASE EJECTOR
#PR3691

SHELL PLATE CARRIER
TR4415

LEVER CLAMP
OF3662

TOGGLE (qty. 2)
OF2853

5/16-18 X 1 1/4 BOLT
F02113

1 1/16" WASHER
OF3609

Bin & Bracket
90687

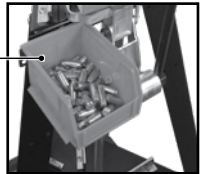

Die wrench included

Works on
spline drive
breech lock
bushings
and lock
rings.



Breech Lock Bushing Die Set

Kits include new Breech Lock Die Set. Smart Lock bushings utilize an integrated o-ring to keep dies firmly in place, yet remain finger adjustable. Color coded for easy identification. The best value for Lee Breech Lock press owners.



See Pg 8

LUBRICATION POINTS= use STP™ motor treatment or motor oil.

SAFETY CONSIDERATIONS

- Be sure of proper powder and charge for bullet weight selected.
- Wear safety glasses and hearing protection when reloading or shooting.
- Be extremely careful to avoid a double charge. If in doubt, empty the case and recycle it.
- Do not permit distractions while loading. This is a complex machine that needs your fullest attention.

SMOOTH OPERATING TIPS

- Always move the lever smoothly in complete strokes. An interrupted stroke can cause a jam or double charge.
- Do not force it or you will break something. If it does not feel right, stop and check out the problem.
- Oil ram using STP™ motor oil treatment. Using any oil, lubricate link bolts and ram pin every few thousand rounds.

SETUP TOOLS REQUIRED

- Safety glasses & ear protection
- 1/2" socket or wrench

HELPFUL SETUP VIDEOS

Open camera application on smart-phone or tablet, hover over the QR code for a direct link to help video.

**PRO 1000
HELP VIDEOS**



- 1** Mount your press. The most convenient way to mount your press is with our **Lee Bench Plate System # 90251**. This system includes all of the mounting hardware and allows for quick press removal without unbolting from bench. Or, purchase (qty. 3) 1/4" bolts and nuts and prepare your workbench for use with this press.

90251 Bench Plate

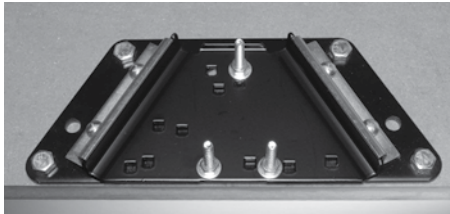

Loosen with a 1/2 inch wrench

- 2** Loosen lever clamp. Re-position handle, tighten securely with 1/2" socket or wrench to 25 ft./lbs.

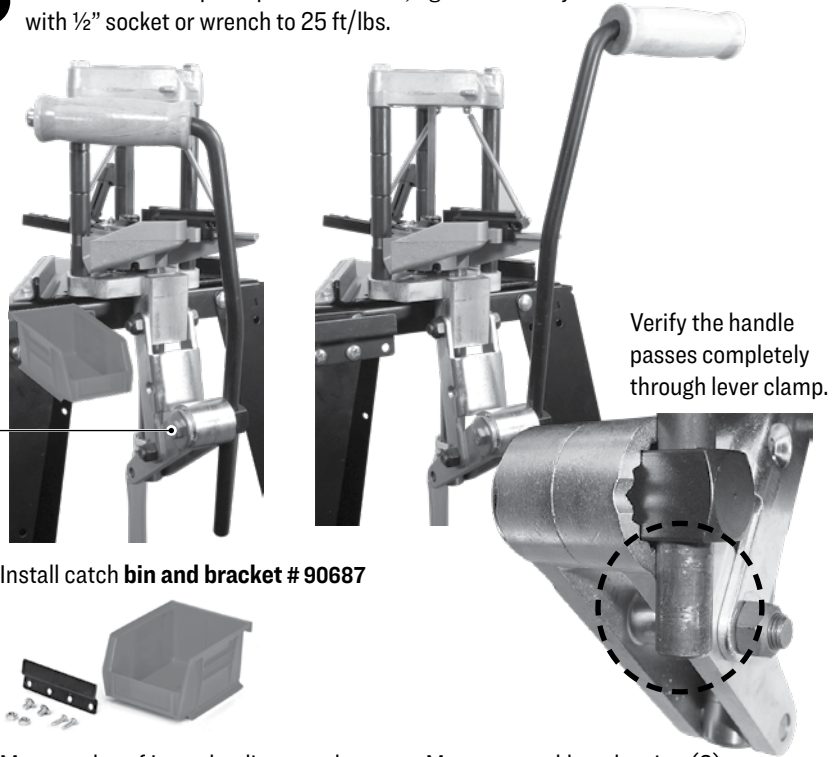

- 3** Raise the retaining ring and slide the primer collection tube assembly into the ram. Slide retaining ring on to assembly.

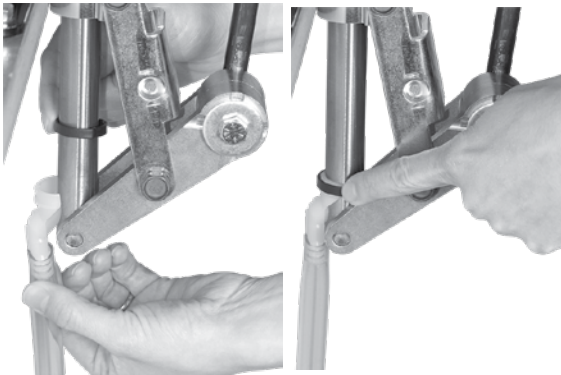

- 4** Install catch bin and bracket # 90687



Mount to leg of Lee reloading stand using provided 1/4"-20" bolts and 1/4"-20 nuts



OR Mount to workbench using (2) provided # 8 Phillips head screws.



TIP If loaded rounds catch in corner of eject trough, add a ziptie to your toolhead to guide the flow to your catch bin.

5 TOOL HEAD POSITION & INITIAL SETUP

LEE BREECH LOCK DIES include Smart Lock bushings on the dies. Lock rings are not required when utilizing these bushings.

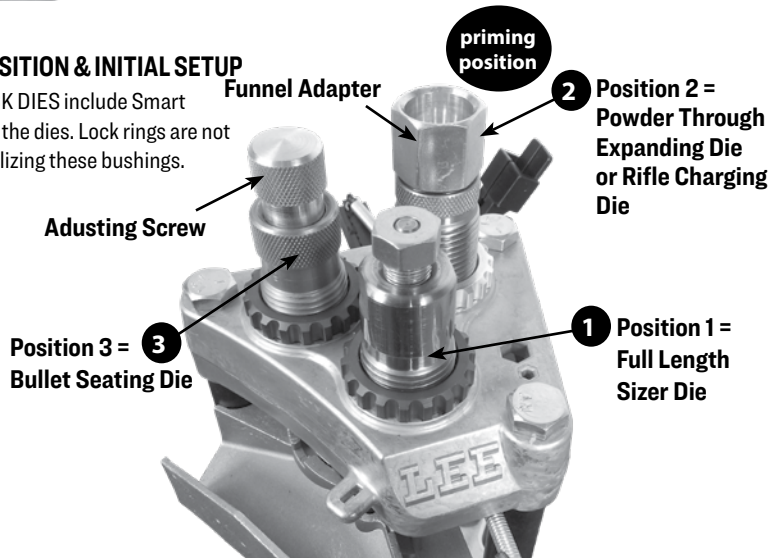

Ziptie

6 PRO 1000 DIE INSTALLATION

Position 1 = Full Length Sizer Die sizing & depriming must be done in this station

- (A) Install die and bushing in tool head position 1.
- (B) Raise the carrier to top of stroke. (Handle down and hold)
- (C) Screw die into contact the shell plate.
- (D) Release lever, screw in the die additional 1/3 turn further.



Note Using a 1/2" (13mm) wrench on the decapper clamp makes adjustment easy.

How to install Smart Lock Bushings

Drop the Smart Lock bushing into the press frame, and rotate the bushing 1/6 of a turn clockwise finger tight. Remove by rotating 1/6 turn counterclockwise and lifting from the frame. To prevent die movement, install and remove by **grasping the spline of the bushing**. A handy die wrench is included.

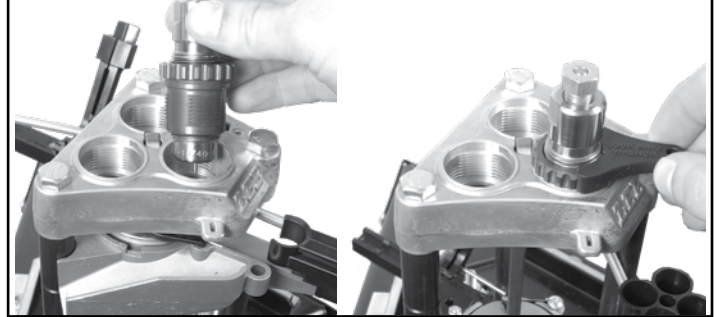

Position 2 = Powder Through Expanding Die or Rifle Charging Die

- (A) Install appropriate die and bushing onto Auto Drum powder measure.
- (B) Insert assembly into position 2.
- (C) Position a case under position 2 and raise to top of its stroke (hold lever down).
- (D) Rotate entire powder measure and die inward until the top of stroke indicator nears the top of the slot in the casting.

NOTE: handgun powder through expanding dies should be installed deep enough to flare case mouth to allow easy insertion of bullets.



Dispense position
Note: slider drop tube should not make contact with top of slot

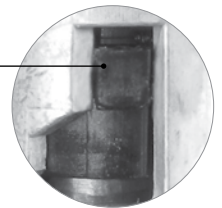

Position 3 = Bullet Seating Die

Install the die and bushing into position 3.



Adjusting
Screw



Handgun
Bullet Seating
Die

7 Installing or Changing Primer Guide

IMPORTANT Do not operate primer feed without a small or large primer guide installed into slider. Doing so will cause damage to your primer slider.

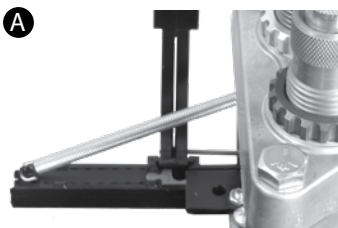

Raise carrier to align primer guide with hole in slider trough (see detailed image pg 8)



Insert a paper clip or small hex key into hole on the underside of primer trough, push primer guide out.

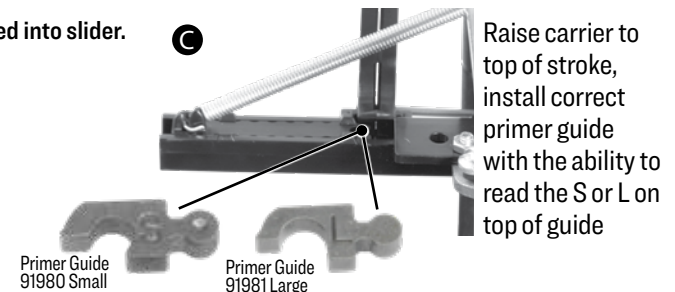

Raise carrier to top of stroke, install correct primer guide with the ability to read the S or L on top of guide

Important!

Do not operate without a small or large primer guide installed into slider.

8 DRY RUN (no primers, powder, or bullets)

Cycle the lever up and down to confirm the shell plate is advancing correctly.

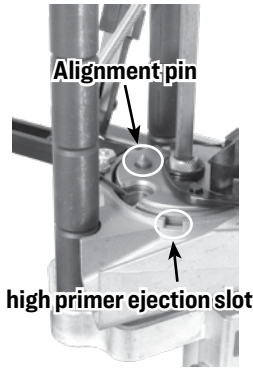

Lower the lever, place a case in front of the slider block and raise lever to insert case into shell plate. Lower the lever and the case is raised into the sizing die position. Lift the lever, the case will advance to the priming station and primer will be seated at the carrier's bottom of the stroke. Lower the lever, the case will rise into station #2, the powder charging and pistol expanding station. Raise the lever and the case will advance to bullet seating/crimping station # 3. Lowering the lever will raise the case into the bullet seating/crimping die to seat the bullet.

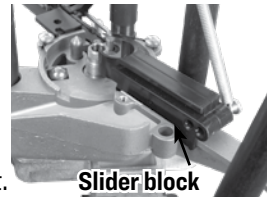

At any time if you need to remove the case, raise the shell plate carrier so that the alignment pin is no longer engaged with the shell plate, you can then rotate the shell plate in either direction to remove the case. Important, if a partially seated primer holds the case in the shell plate, simply rotate the shell plate to the high primer ejection slot and remove. Whenever the normal reloading sequence is interrupted, the most important hazard to guard against is a double charge. It is always best to completely remove the offending case.

9 Fill the primer feed tray.

Don't let the primer level fall below the tray level. Running out of primers will cause a mess inside your shell plate carrier. Once the last primer has exited the folding tray, replenish the primer supply, or else you will be loading cases without primers.

View help video for loading primers into tray:



! DANGER: Primers can explode with sufficient force to seriously injure the user or persons nearby.

ALL PRIMERS ARE DANGEROUS and it should be anticipated that the primers in the tray could explode through accident, misuse or spontaneously. Should an explosion occur, our tests have demonstrated that safety glasses will normally prevent serious injury to the user. Primers are capable to explode with sufficient force to seriously injure the user, or persons nearby. When loading primers—safety glasses and hearing protection must be used. Observe the warnings on the primer box.

! WARNING: Handling live primers and spent primers may expose you to lead or other chemicals, which are known to the State of California to cause reproductive harm and cancer. For more information, go to www.P65Warnings.ca.gov.



Slide the flow control to **OPEN**.

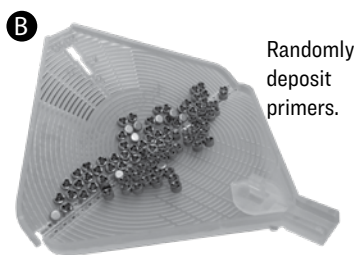

Randomly deposit primers.

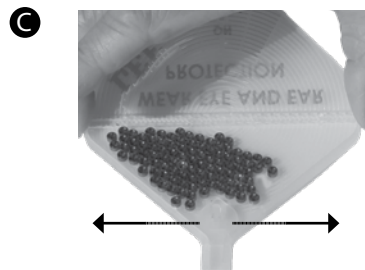

Lift tray so output spout touches table, shake tray side to side to upright all the primers. Allow cover to naturally fold up, notice how the primers glide across hinge upright themselves and work their way to wards the outlet.



Fold cover over, slide the flow control to **LOCK** position, feel for the detent. Grasp the top and bottom of the flow control valve using your thumb and index finger above and below tray.

NOTE: make sure it is in the LOCK detent position, or else primers may spill.

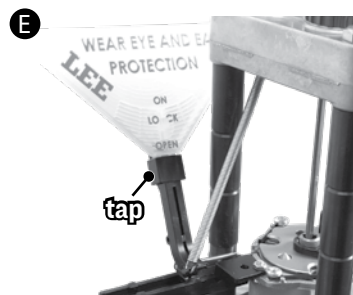

Slide the tray into the trough. Slide the flow control to the **ON** position. Tap the side of the trough several times to fill the trough.

IMPORTANT: the primer is seated during the last inch of lever travel. Make a conscious effort to feel the primer enter and fully seat into the case. Incomplete primer seating will not allow the case to eject from the shell plate. This seems to be the biggest problem for first time users.



Lift firmly on lever to seat primer

Don't install the case feed magazine until you are confident of the operation.

If you are just starting on a progressive press, we suggest you start out using the Pro 1000 as a single stage press by producing one round at a time with three cycles of the lever. Install the 3 dies in the press as instructed. Drop an empty case into the case feeder and cycle the lever three times.

Before attaching the 4 tube case feed magazine, process 50-100 cases until you have the feel of the entire reloading sequence. Be sure to measure your completed ammunition to verify it is the correct overall length and will chamber in your firearm.

Once you are comfortable and the press is functioning smoothly you can use the press as a full progressive by simply placing a case in front of the case slider every cycle of the lever. Because each station performs one operation, every time you cycle the lever you produce a finished round. If you operate the lever at a leisurely 10 seconds per cycle that is 360 rounds an hour.

CASE FEED MAGAZINE

10 INSTALLING Universal Case Feed Magazine

This accessory will greatly simplify progressive reloading placing a case every time the press is cycled. The case slider block and riser is installed on your press. Shorter cases will require you to remove the riser from the case slider block. All you need to do is install the feed plate configured for the case that you will be loading.

- A** See chart on page 8, some cases require riser to be removed from top of case slider block.

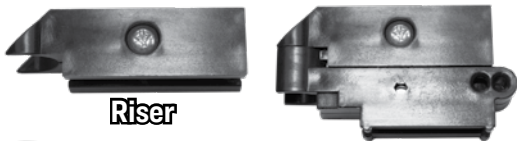

Riser



Case slider block

If utilizing the **RISER**, verify **CASE SLIDER BLOCK** front and back are flush. Tighten Phillips screw on riser block.

- B** Confirm case feed spring is attached to rear hole of case slider

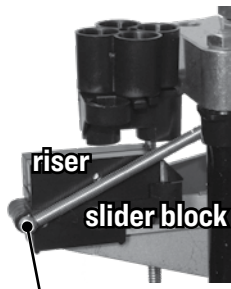

riser

slider block

use rear hole



Consider the case collator product # 90667 fill all four case feed tubes in as little as 10 seconds.

Case Collator # 90667

- C** See chart on page 8. Install the correctly configured feed plate (large or small) keeping the bottom of the case feed plate a pennies thickness above the case mouth. Slide a case through feed plate. Place penny on top of the case, slide feed plate into carrier.

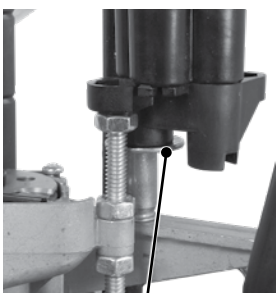

A penny's thickness above case mouth

Reference grid on pg. 8 for setup instructions

Assembled as a **SMALL** feed plate

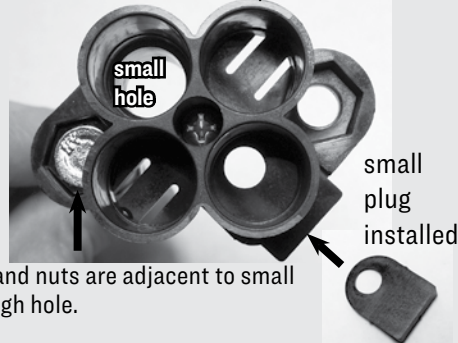

Bolt and nuts are adjacent to small through hole.

Assembled as a **LARGE** feed plate

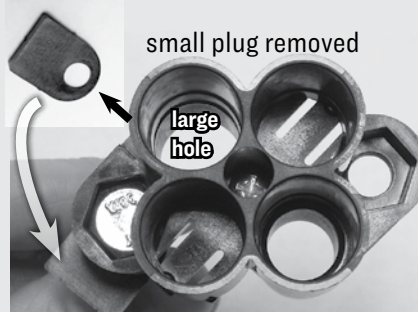

Bolt and nuts are adjacent to large through hole.



storage spot for small plug

- D** Secure the feed plate with a nut above and below the carrier slide rail. Tighten 7/16" nut below carrier to secure.

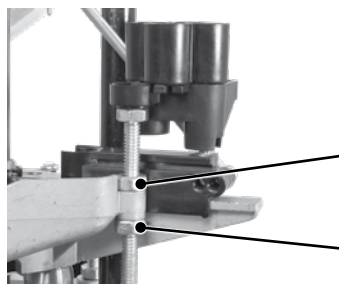

TROUBLESHOOTING

PROBLEM	CAUSE	REMEDY
Primers not fully seated	<ul style="list-style-type: none"> Operator not lifting hard enough Shell plate carrier not fully seated or loose on ram Obstruction to full travel 	<ul style="list-style-type: none"> Learn to feel the primer seating when the lever is pushed up Loosen socket head cap screw and force shell plate carrier on the ram. Re-tighten clamp screw Check for primer on base or under shell plate carrier. Carrier should contact the base with no case in the shell holder
Primer doesn't feed onto priming punch	<ul style="list-style-type: none"> Oil or gunpowder in trough Primer trough not full 	<ul style="list-style-type: none"> Remove all oil with solvent or blow out powder or dust with compressed air Always keep primer trough full
Primer doesn't enter case	<ul style="list-style-type: none"> Primer crimp not removed Wrong size primer 	<ul style="list-style-type: none"> Ream or swage primer pocket Caution, some 45 ACP cases now have small primer pockets
Tipped primers	<ul style="list-style-type: none"> Case not fully in shell plate Spilled powder in primer trough 	<ul style="list-style-type: none"> Clean shell plate. Check tension finger. Straighten or replace tension finger as required Clean powder out with compressed air
Cases don't eject	<ul style="list-style-type: none"> Primers not fully seated 	<ul style="list-style-type: none"> See "Primer not fully seated" problem above
Cases don't slide out	<ul style="list-style-type: none"> Cases catch in corner of eject trough 	<ul style="list-style-type: none"> Place 6" ziptie in toolhead slot. See Fig. 1
Case feeder doesn't work properly	<ul style="list-style-type: none"> Case feed spring in wrong case slider hole 	<ul style="list-style-type: none"> See case feed position photo. Spring should be installed into rear hole. See Fig. 2
Press does not index	<ul style="list-style-type: none"> Worn driver clutch 	<ul style="list-style-type: none"> Rotate driver clutch 90° or replace driver clutch (part # PR3691). See Fig. 3

Fig. 1



Fig. 2

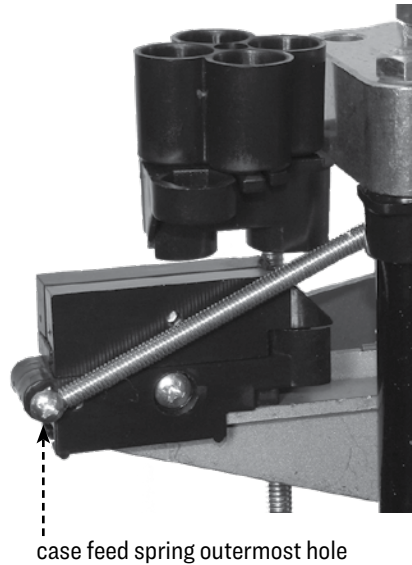

Fig. 3

A Remove index rod



B With a stubby #2 Phillips screwdriver, loosen clockwise and remove 1 of the 8-32 x 1/4 Pan HD screws on the clutch retainer plate.



C Pull down retainer plate and rotate driver clutch or replace. Re-install clutch retainer plate screw and index rod.



Driver Clutch
(part # PR3691)



Changing shell plate



Remove Smart Lock bushing from station 2.

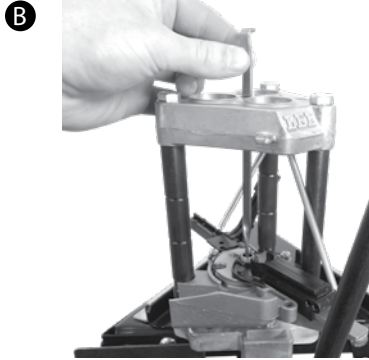

With the carrier at the bottom of the stroke (handle up), remove index rod.

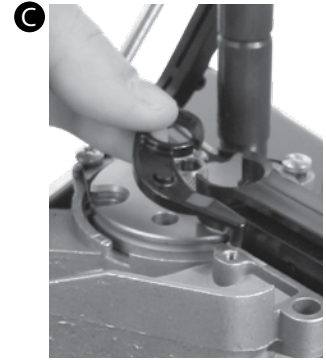

Remove case ejector



Loosen turning clockwise with a 1/4 inch hex key while holding the shell plate

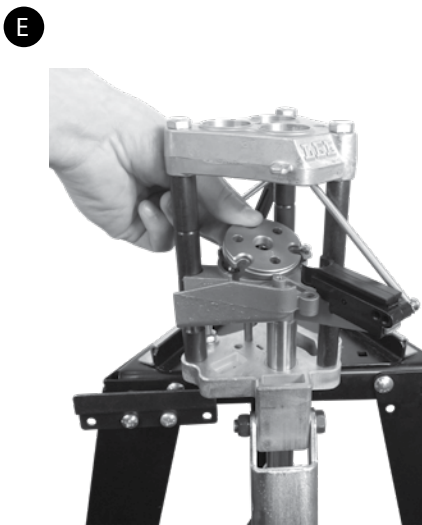

Remove shell plate.

**PRO 1000
HELP VIDEOS**



SHELL PLATE CARRIER DETAIL

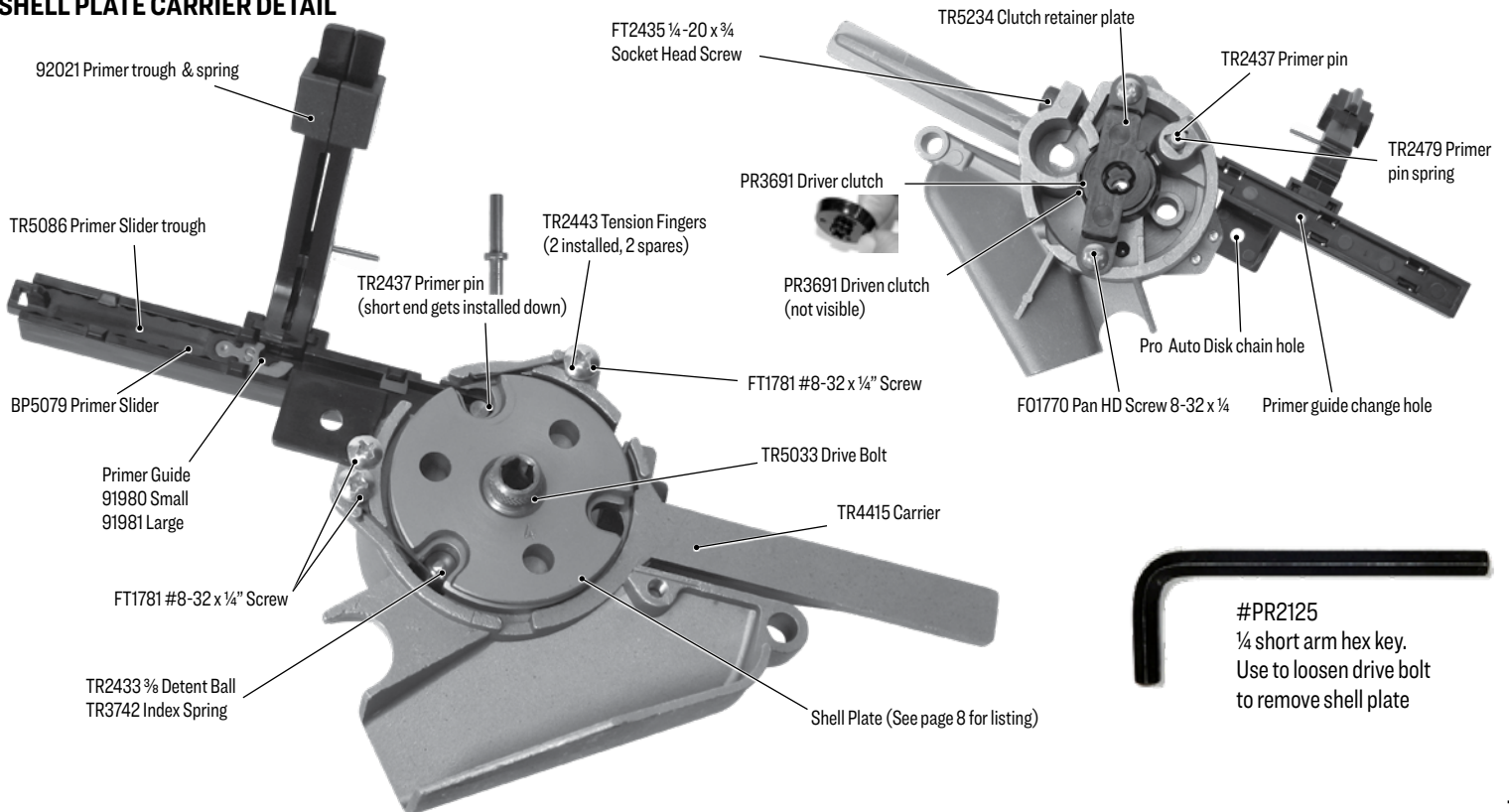

CARTRIDGE CHANGE OVER

To convert the Pro 1000 from a one cartridge to another, you will need the proper shell plate and appropriate Lee reloading die set. The chart below shows proper configuration with catalog numbers.

Cartridge	Shell Plate	Shell Plate Product #	Univ. Case Feed Plate Size	Univ. Case Feed Slider Block	Reloading Dies	Bushing set needed	Charging die	Primer Guide
30 Luger	19	90669	SMALL	N/A	90754	Yes		Small
30 Mauser	19	90669	SMALL	N/A	90755	Yes		Small
7.62 Tokarev	19	90669	N/A	N/A	90769	Yes		Small
32 ACP	7S	90655	SMALL	N/A	90622	Yes		Small
32 S&W Long	4AS	90653	SMALL	N/A	91876	No		Small
32 H&R MAG / 327 FED	4AS	90653	SMALL	N/A	90809	Yes		Small
9mm Luger	19	90669	SMALL	N/A	91882	No		Small
9mm Makarov	19	90669	SMALL	N/A	90176	Yes		Small
32/20	6S	90976	SMALL	N/A	90751	Yes		Small
357 Sig	19	90669	SMALL	N/A	90270	Yes		Small
38 Super	19	90669	SMALL	N/A	91879	No		Small
38 S&W	1S	90651	SMALL	N/A	90569	Yes		Small
380 Auto	4S	90653	SMALL	N/A	91877	No		Small
38 SPL & 357 MAG	1S	90651	SMALL	RISER	91878	No		Small
38 ACP	19	90669	SMALL	N/A	91879	No		Small
38 Short/Long COLT	1S	90651	SMALL	N/A	90276	Yes		Small
40 S&W	19	90669	SMALL	N/A	91880	No		Small
10mm Auto	19	90669	SMALL	N/A	91880	No		Large
41 Mag	9L	90656	LARGE	RISER	90628	Yes		Large
44 SPL & 44 MAG	11L	90657	LARGE	RISER	91881	No		Large
400 Cor Bon	2L	90652	LARGE	N/A	90430	Yes		Large
30M1	7S	90655	SMALL	RISER	90626	Yes		Large
44 Russian	11L	90657	LARGE	RISER	90293	Yes		Large
44-40 WIN	14S	90065	LARGE	RISER	90564	Yes		Large
454 Casull	11L	90657	LARGE	RISER	90795	Yes		Large
45 ACP	2L	90652	LARGE	N/A	91883	No		SM / LG
45 Auto Rim	13L	90665	LARGE	N/A	90808	Yes		Large
45 Colt	11L	90657	LARGE	RISER	91884	No		Large
45 Schofield	14	90065	LARGE	RISER	90323	Yes		Large
45 GAP	2L	90652	LARGE	N/A	90498	Yes		Small
45 WIN MAG	3L	90664	LARGE	RISER	90810	Yes		Large
460 S&W	14S	90065	LARGE	RISER	90344	Yes		Large
50 Action Express	11L	90657	N/A	N/A	90329 (LUBE REQ.)	Yes		Large
223 REM	4S	90653	SMALL	RISER	91885 (LUBE REQ.)	No	90668	Small
300 AAC Blackout	4S	90653	SMALL	RISER	91925 (LUBE REQ.)	No	90668	Small
7.62 x 39	12L	90666	SMALL	RISER	90565 (LUBE REQ.)	Yes	90668	Large
222 REM	4S	90653	SMALL	RISER	90501 (LUBE REQ.)	Yes	90668	Small
458 SOCOM	2L	90652	N/A	N/A	90409 (LUBE REQ.)	Yes		Large

N/A = Not available LUBE REQ. = # 90006 LEE resizing lubricant required

The Lee Guarantee

LEE RELOADING PRODUCTS are guaranteed not to wear out or break from normal use for two full years or they will be repaired or replaced at no charge if returned to the factory. Any Lee product of current manufacture, regardless of age or condition, will be reconditioned to new, including a new guarantee, if returned to the factory with payment equal to half the current retail price.



WARNING: Handling live primers and spent primers may expose you to lead or other chemicals, which are known to the State of California to cause reproductive harm and cancer. For more information, go to www.P65Warnings.ca.gov.



WARNING: This product may contain steel alloyed with trace amounts of lead and other elements which are known to the State of California to cause reproductive harm and cancer. For more information, go to www.P65Warnings.ca.gov. To prevent exposure, do not alter the product by welding, grinding, etc.