

SUPER SABRA TRIGGER PACK

FOR IWI TAVOR RIFLES

Installation Instructions

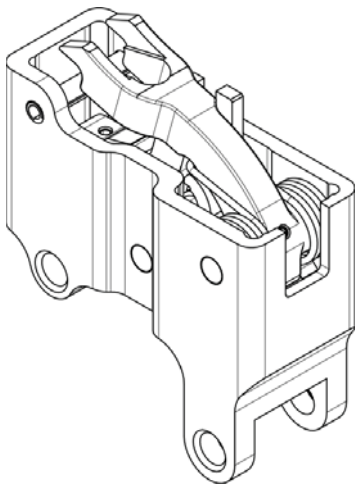

GEISSELE[®]
AUTOMATICS
We Manufacture Confidence[®]

READ THIS FIRST

Firearm safety is **YOUR** responsibility. You must memorize and put into practice the 4 Rules of Firearm Safety.

1. Assume every weapon is loaded.
2. Keep your finger off the trigger until you are ready to shoot.
3. Do not let the muzzle point at anything you are not willing to destroy.
4. Know your target and what is beyond.

The Geissele Automatics Super Sabra Trigger will lighten the trigger pull relative to a standard trigger. This lightened trigger pull will make the firearm easier to discharge. You must recognize and accept this fact before installing this trigger. If you do not want a lighter than standard trigger pull or are not willing to accept responsibility for the safety of your firearm, yourself, and those around you, do not install this trigger. Geissele Automatics recommends installation only by a certified gunsmith.

INSTALLATION INSTRUCTIONS

1. Unload rifle and make safe.
2. Pull charging handle to cock the hammer in the current trigger pack.
3. Using a punch, press out the two captured retaining pins that hold the trigger pack in place. With these pins removed the trigger group should easily slide out the bottom of the rifle.
4. Confirm the Geissele Super Sabra trigger pack has been lubricated. If so, insert the trigger pack making certain the hammer is cocked and facing forward.
5. Re-insert the retaining pins.

Adjusting First Stage Pull Weight

The Geissele Super Sabra trigger has an adjustable first stage from 3.5 to 5.5 pounds. From the factory the trigger is preset to the minimum 3.5 lbs on the first stage.

To adjust, locate the adjustment screw on the bottom of the trigger housing. If the user wishes to increase the first stage the screw should be turned clockwise. To prevent coil bind on the trigger spring the screw should not be turned more than four turns from flush.

To lower the first stage pull weight the adjustment screw can be turned counter-clockwise. The minimum first stage is achieved with the adjustment screw flush with the housing. **DO NOT** adjust the screw out further than flush as the screw will interfere with the bolt catch lever.

FIRST STAGE
ADJUSTMENT SCREW

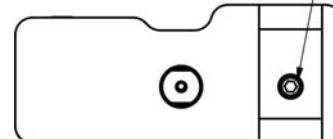

Basic Function Check

After the trigger pack has been inserted, the user should complete a basic function test.

1. Confirm weapon is unloaded and safe.
2. Check safety operation: With the hammer cocked and the safety selector to the SAFE position, pull the trigger hard. The hammer should not fall.
3. Check trigger reset: With the hammer cocked, set the safety selector to FIRE. Dry fire weapon and keep trigger held back. Pull charging handle all the way back and release, letting the bolt carrier snap forward. The hammer should not fall. Release trigger and make sure the hammer is caught by the trigger.

Maintenance

Maintenance of the Geissele Super Sabra consists of occasionally placing a drop of lubricant on the locations shown below. Recommended lubricant is CLP or a high quality grease on the trigger/hammer sears and disconnector contact surfaces.

When the trigger pack becomes very dirty (such as when firing with a suppressor), it may be necessary to remove, but not disassemble, the trigger group for cleaning. Spray down the trigger group with electrical contact cleaner to remove residual oil and dirt. Next, use compressed air to blow off the trigger group and then flush liberally with a light lubricant. Blow off excess lubricant with compressed air and lubricate as noted below.

At no time should the trigger components be removed from the housing.

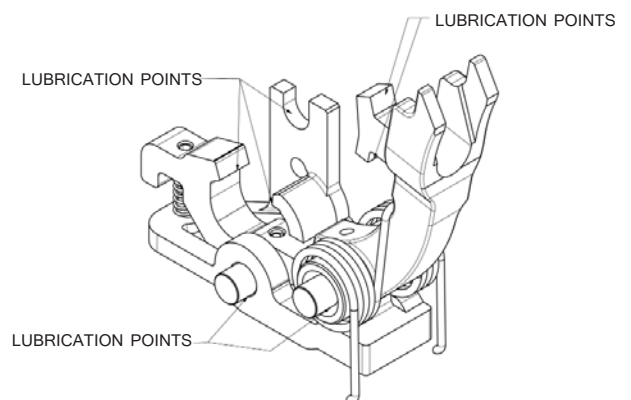

TRIGGER PACK SHOWN WITHOUT HOUSING FOR CLARITY. REMOVAL OF COMPONENTS NOT REQUIRED.

Contact Geissele Automatics with any questions.

Geissele Automatics, 800 North Wales Road, North Wales, PA 19454
Tel: 610-272-2060 | Fax: 610-272-2069 | E-mail: info@geissele.com
Please visit our website at www.geissele.com